



Page 72

## FEATURES

### 26 The Design Legacy of Ed Burnett

A search for perfection

*Nic Compton*

### 34 Aboard: PANACEA

Ed Burnett's 24' pocket cruiser

*Nic Compton*

### 38 The State of the Art of Recreational Rowing

Why wood works

*Carl Kaufmann*

### 48 Hai Times on the Baltic

The roots and legacy of a classic Finnish one-design

*Greg Smith*

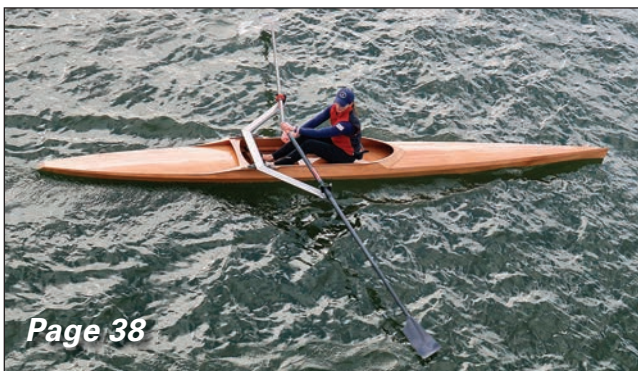

Page 38

### 58 A Builder's Theory of Beauty

A meditation on mistakes, admiration, and the quest for harmony

*Lawrence W. Cheek*

### 64 The New World Coracle

Improvisation with willow

*Hilary Russell*

### 66 The Basket as Boat

Construction highlights of willow-framed hulls

*Hilary Russell*

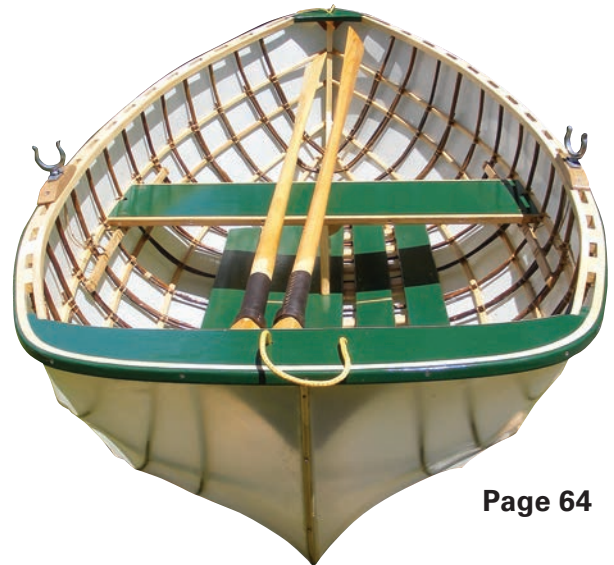

Page 64

### 72 New Spars for ZISKA

Using bird's-mouth joints in large work

*Pat Mahon*

### 80 Australian Wooden Boat Festival 2019

A sense of place on the far side of the world

*Matthew P. Murphy*

### 86 LADY FREE

A Norwegian pilot boat circumnavigates the Americas

*Bruce Stannard*

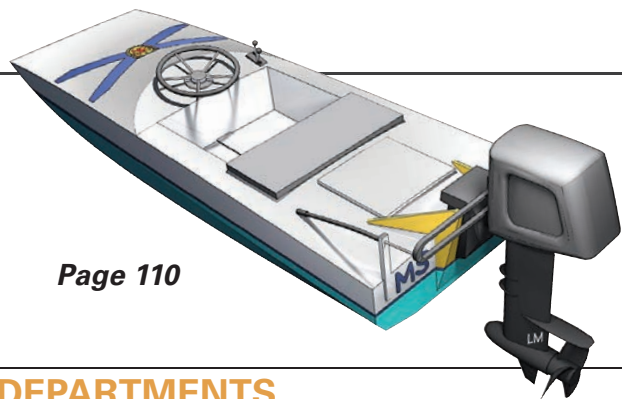

Page 110

## DEPARTMENTS

### 6 Editor's Page

Small-World Stories

### 8 Letters

### 14 Currents

*edited by Tom Jackson*

### 46 Wood Technology

More on Paddles and Oars

*Richard Jagels*

### 92 Review

*L. Francis Herreshoff, Vol. 2* Dan Brayton

Rubbed-Effect Varnish Greg Rössel

Books Received

### 100 Launchings...and Relaunchings

*Robin Jettinghoff*

### 104 Designs: Review

Little Crab

*A 13' Sailing Skiff*

*Mike O'Brien*

### 110 Designs: Sketchbook

MS NOVA SCOTIA

*An updated Mini Max Seaflea*

*Laurie McGowan*

### 140 Save a Classic

BEN GUNN

*A fishing cruiser by Wells and Jacob*

*Maynard Bray*

## READER SERVICES

116 Brokers

121 Builders

126 Kits & Plans

130 Raftings

132 Classifieds

139 How to Reach Us

139 Index

## TEAR-OUT SUPPLEMENT Pages 16/17

### Getting Started in Boats

First-Aid Kits

*Shelly Galligan*

*illustrations by Jan Adkins*

**Cover:** PANACEA, a 24' cutter built by Ben Harris to a design by Ed Burnett, sails on Carrick Roads in England before being shipped to Perth, Australia, last year.

**Pages 26 and 34.**

*Photograph by  
Nic Compton*



**WoodenBoat** (ISSN 0095-067X) is published bimonthly in January, March, May, July, September, and November in Brooklin, Maine, by WoodenBoat Publications, Inc., Jonathan A. Wilson, Chairman. Subscription offices are at **P.O. Box 292859, Kettering, OH 45429-0859; 1-800-877-5284** for U.S. and Canada. Overseas: 1-937-610-0234.

Subscription rate is \$34.00 for one year (6 issues) in the U.S. and its possessions. Canadian subscription rate is \$39.00, U.S. funds. Surface rate overseas is \$47.00, U.S. funds per year. Periodical postage paid at Brooklin, ME 04616 and additional mailing offices. In Canada, periodical postage paid at Toronto, Ontario (Canadian periodical Agreement No. 40612608, GST Registration No. R127081008).

**U.S. Postmaster:** Please send Change of Address (form 3579) to P.O. Box 292859, Kettering, OH 45429-0859.

**Canada Postmaster:** Imex Global Solutions, P.O. Box 25542, London, ON, N6C 6B2, Canada.